







Product Range	Power (W)	Standard 	Standard & Sensor 	Dali 	 Emergency 	 Emergency & Sensor 
Large Otford	10	6.25	6.25	6.5	6.75	6.75
	20					
Small Otford	10	5	5	5.25	5.5	5.5
	20					



**6c** ⚡/⚡ & Sensor

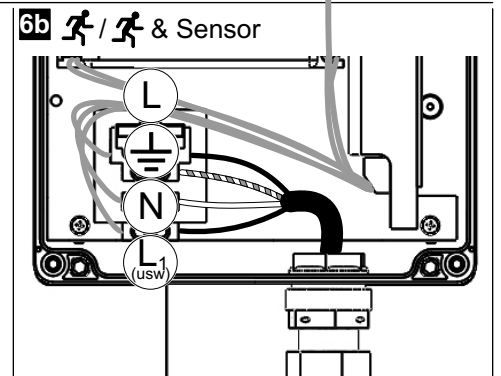
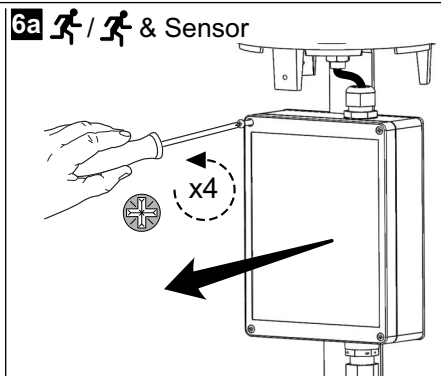
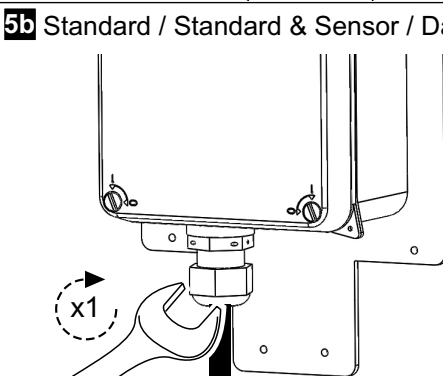
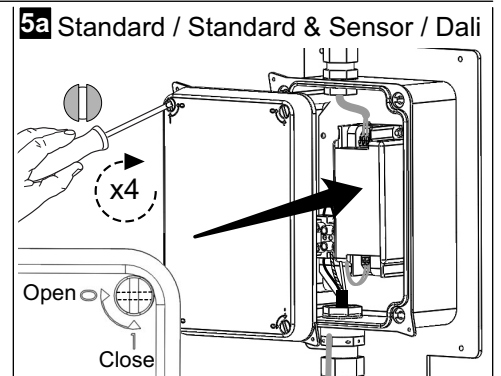
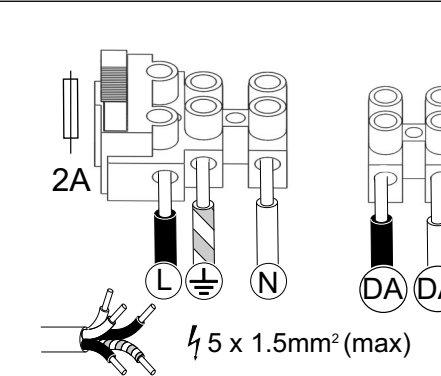
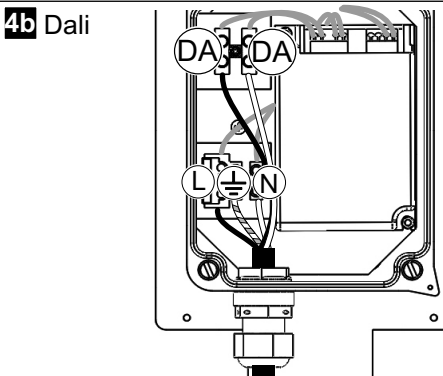
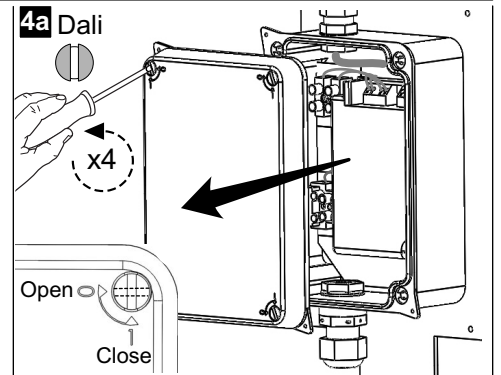
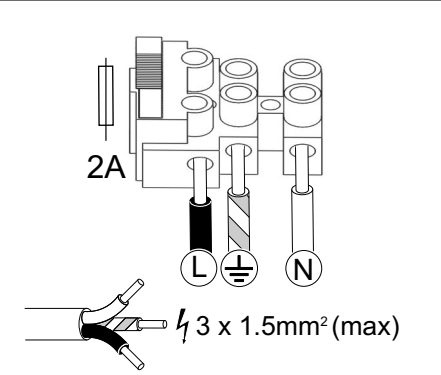
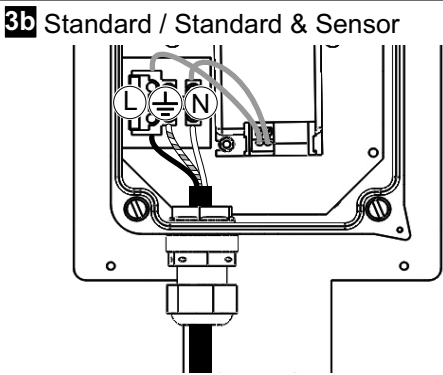
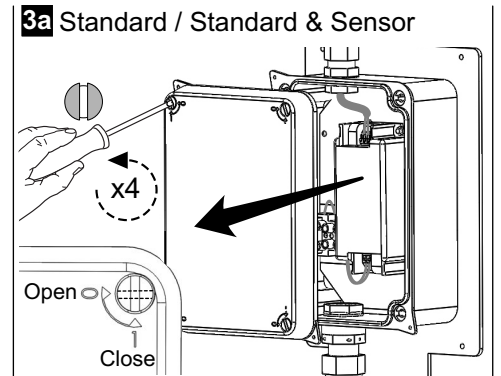
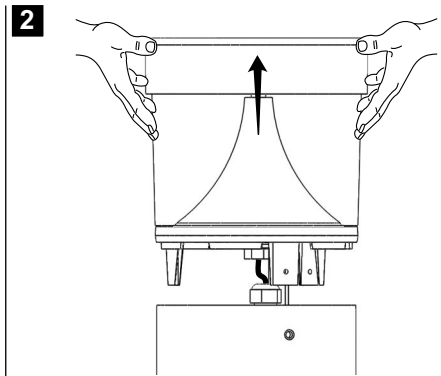
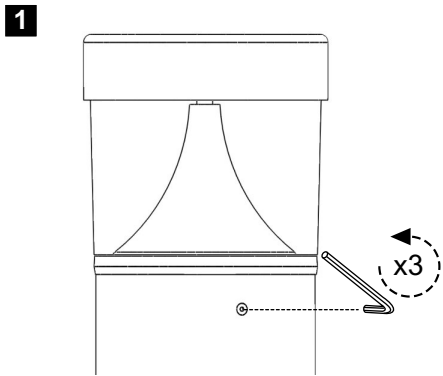
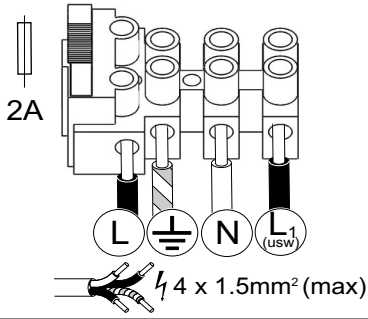

**6d** ⚡/⚡ & Sensor

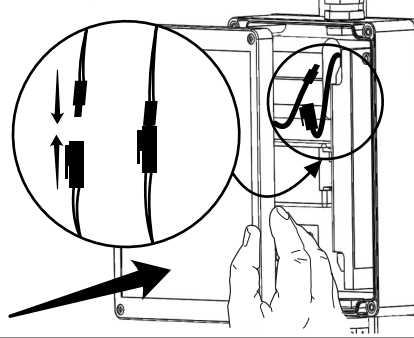

**6e** ⚡/⚡ & Sensor

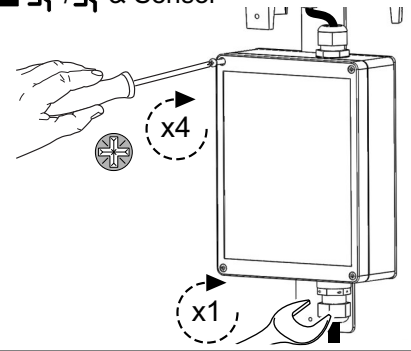

**7** Standard & Sensor / ⚡ & Sensor

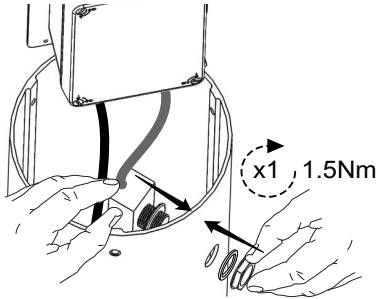

**8**

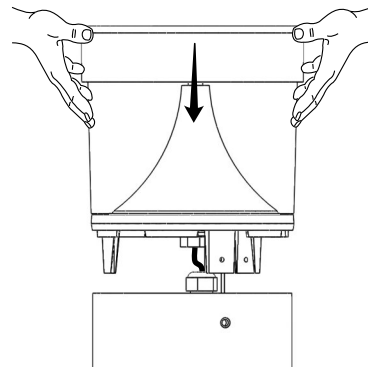

**9**

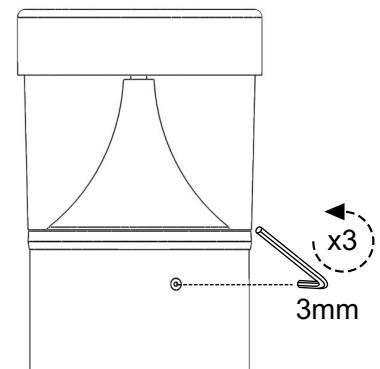

**10a** FIX0054

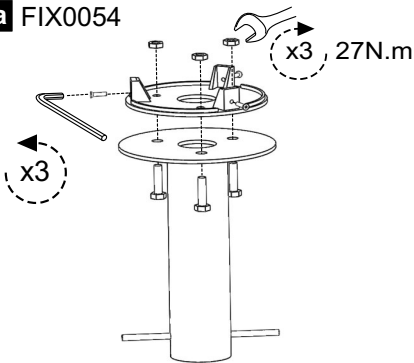

**10b** FIX0054

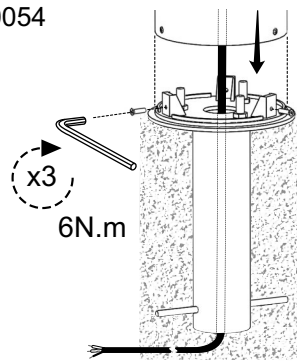

**11a** FIX0053

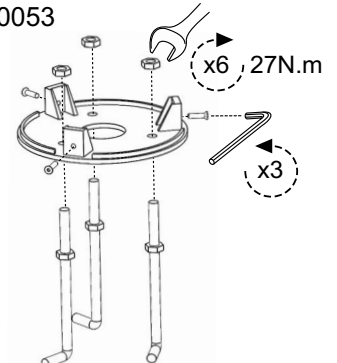

**11b** FIX0053

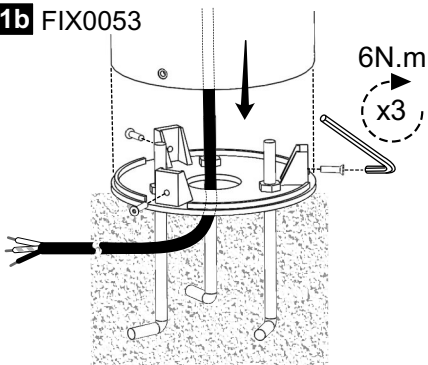

**Optional mounting**

Root Mounting (Standard)  
Flange Plate + Root Mount  
(FIX0054)

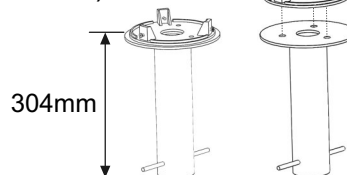

Flange Plate + Bolts (FIX0053)

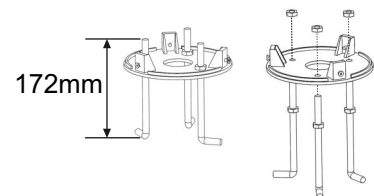

**Operation & Maintenance**

Failed light source should be replaced promptly or the circuit switched off to avoid possible damage to control gear.

**Important - Safety**

Before carrying out any servicing on these luminaires, ensure that the mains supply is fully isolated.

Disconnect the luminaire before insulation testing of the installation.

Circuit Breaker Type	B10	B16
Standard / ⚡ 10W Luminaire	60	100
Standard / ⚡ 20W Luminaire	30	50
Dali 10W Luminaire	90	160
Dali 20W Luminaire	45	80



The light source contained in this luminaire shall only be replaced by the manufacturer or his service agent or a similar qualified person.



FM57330