

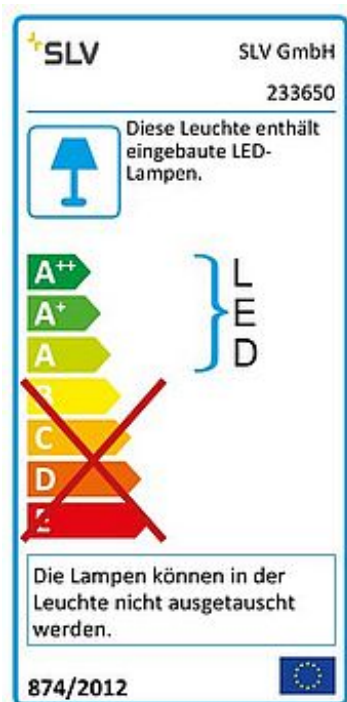

BRICK

outdoor recessed wall light, LED, 3000K, stainless steel, IP67, 230V, 950lm 10W



Article number	233650
Product family	BRICK
Feed-in capability	No
Lamp included	No
Installation length	19.6 cm
Installation width	8.5 cm
Installation depth	10.3 cm
Length	21 cm
Width	9.1 cm
Depth	9.3 cm
Net weight	1.78 kg
Gross weight	1.865 kg
Voltage	220-240V ~50/60Hz sec. 700mA
Protection class	I
IP-rating	IP 65
Beam angle	40 Degree
Average lifespan	25000 Hours
Colour temperature	3000 Kelvin
Colour rendering index	80
Luminous flux	950 lm
Energy efficiency class	A++
Colour	Stainless steel
Form	square
Light distribution type 1	direct
Material	Aluminium / Stainless steel 316L / Glass

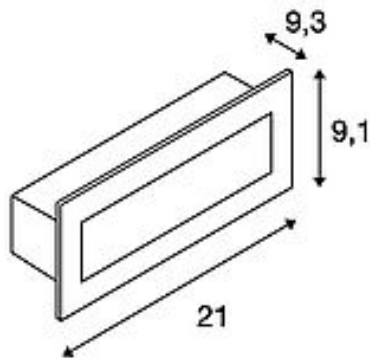

Articles of this series

-
- | | |
|--------|--|
| 229062 | BRICK DOWNUNDER, outdoor recessed wall light, C35, IP44, silver-grey, max. 40W |
|--------|--|
-
- | | |
|--------|--|
| 229110 | BRICK MESH, outdoor recessed wall light, LED, 3000K, IP54, stainless steel, 4W |
|--------|--|
-
- | | |
|--------|--|
| 229702 | BRICK DOWNUNDER, outdoor recessed wall light, LED, 3000K, IP54, rectangular, silver-grey |
|--------|--|
-
- | | |
|--------|---|
| 233660 | BRICK, outdoor recessed wall light, LED, 3000K, stainless steel, 230V, IP67, 850lm, 10W |
|--------|---|

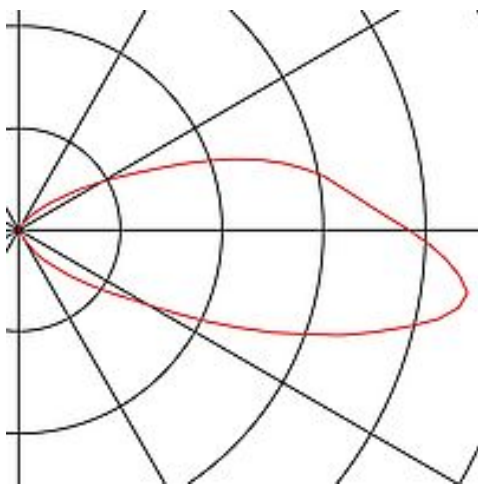

With the BRICK LED recessed wall light, which is made of stainless steel and aluminium, the built-in LEDs are covered by a glass sheet. The built-in reflector means that the light is output symmetrically. The functional luminaire is connected directly to the 230V mains supply. With IP65 protection class, the luminaire is suitable for outdoor use. A mounting pot is included in the delivery for simple assembly. This luminaire contains built-in LED lamps. EEL: A - A++. The lamps in the luminaire cannot be replaced.

Notes
