

EP91540- Vulcan LED Recessed Spotlight - 24v- DC-15w-1380lm-40°-3000K-IP67-Stainless Steel

Description

Vulcan LED recessed light combines a cool toughened glass lens, long lamp life (built-in LED) and energy efficiency for uplighting trees from lawns or paving. This outdoor recessed LED light provides a powerful 40° uplighting beam, using 1 x 15w CREE LED featuring a tempered glass lens that's cool to touch (under 40°C) allowing the Vulcan to be installed safely in walkover areas to uplight trees with an open canopy and branch structure from directly below. The shallow depth and no need to enter the Vulcan fitting for lamp installation or replacement make outdoor recessed LED lighting quick and easy to fit unlike its metal halide cousins. Vulcan has a 316 stainless steel lens rim, a cast aluminium body and a polymer sleeve for recessing into the ground.

Electrical	24v built in 15w 1380lm LED 3000k 40° beam angle
Colour/ Finish	316 grade stainless steel
Exterior Dimensions	Stainless steel top of 108mm and body 100mm long. Sleeve 102mm x 123mm

24v	Pre-wired 2m
IP67	Built-in LED

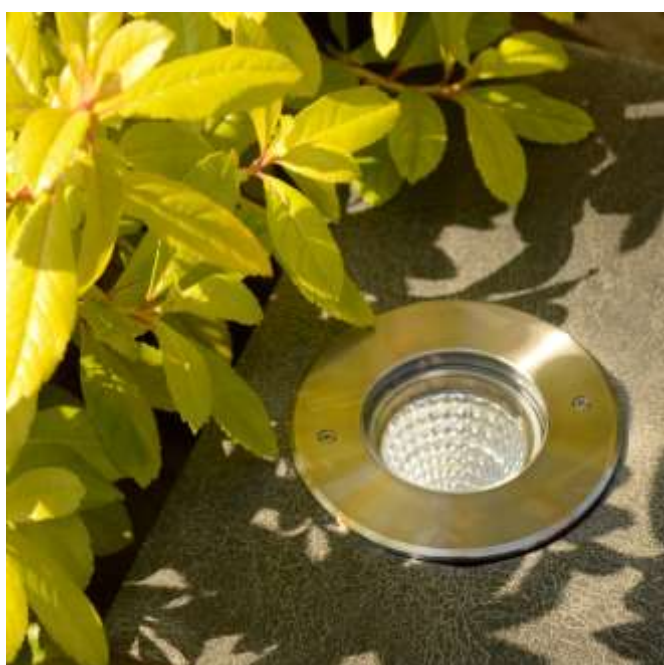

Direct burial in the ground: prewired with rubber cable and 20mm IP68 gland for connection to a 24v transformer via a separate underground joint kit (order T9969 separately). Provide 300mm depth of shingle drainage below the uplight: do not use in waterlogged ground.

The installation sleeve is built into the floor/paving during construction or retrofitted into a hole cut with a coring bit: the light pushes into the tube, where it is held firmly in place by an 'o' ring.

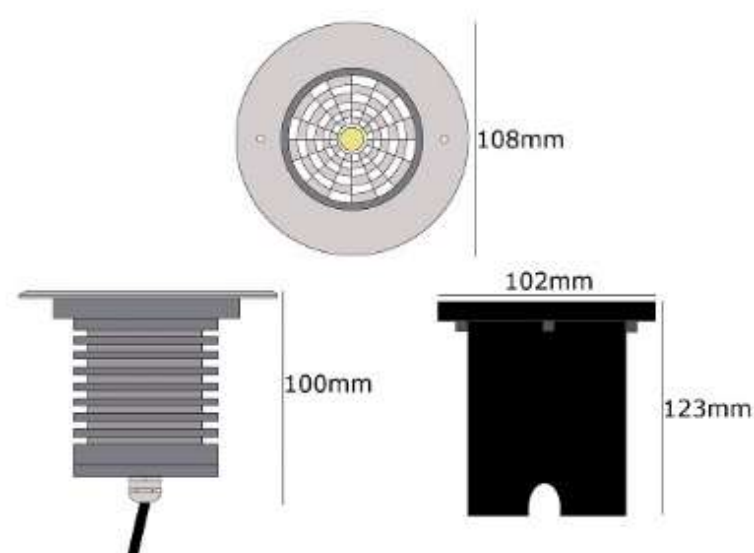

3 YEAR WARRANTY

Exclusions: Damage by machinery, animals or the use of incorrect cleaning materials. Damage due to incorrect installation practices. Responsibility for 3rd party cost; indirect or consequential loss.